



TORX PLUS[®]

The drive system that is gentle on tools

- + 100% longer bit life
- + Optimum tool seating when power-drive
- + 20 % better torsion resistance in driving tools
- + Compatible with the conventional TORX drive system

➔ www.arnold-fastening.com



The new TORX PLUS® drive system gives up to 100% longer service life for screwdriver bits

TORX PLUS® with its special engineering design features.

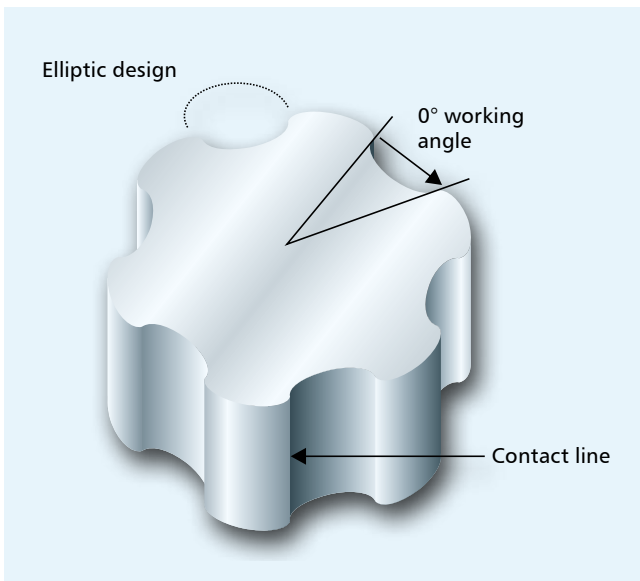

TORX PLUS® provides these advantages, because of the following design characteristics:

- ⊕ The actual working angle is 0°
- ⊕ Larger cross-section on cam faces
- ⊕ Lower chamfering on application of force

Where TORX PLUS® drivers are used the head height can be minimised, thus reducing the overall weight of the component. This is made possible with the improved force application process, which ensures decreased penetration depth.

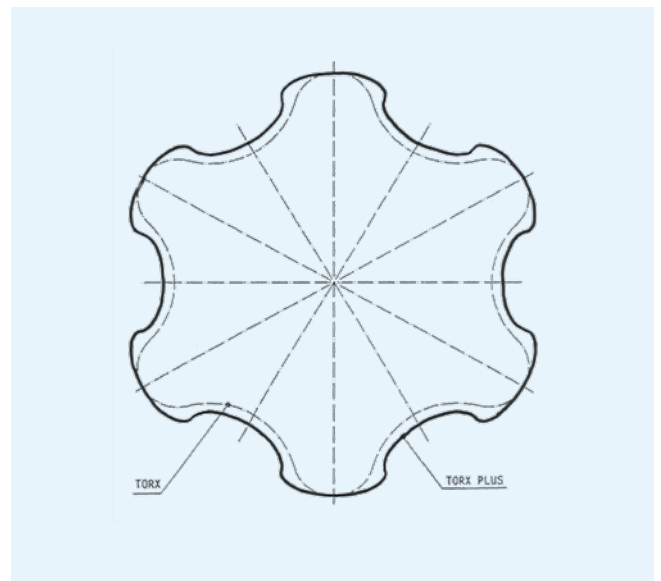

Further advantages of the TORX PLUS® driver system:

- ⊕ 25% improvement on average torsion resistance in screwdriving tools
- ⊕ Improved tool seating when power-driving the screw
- ⊕ Compatible with existing tools on TORX® screwdriving system, so no maintenance problems with existing TORX® applications

Calculation basis:

A ratio of minimum 1.0 to 1.0 between the thread tension surface and head tension surface was established as the standard head height combined with TORX® with regard to an optimal residual base thickness.

Of course TORX PLUS[®] also provides the well-known advantages that distinguished the TORX[®] driver system.

- ⊕ Low axial forces required
- ⊕ Fatigue-free working
- ⊕ No damage to surface
- ⊕ High breakaway torques
- ⊕ No tool slippage

From this we derive the following assembly advantages

- Downtime minimised due to longer tool life
- Improved assembly reliability between tightening and breaking torques
- Screwing conditions improved with improved assembly tool seating

Maximum force transfer of different screwdriving systems

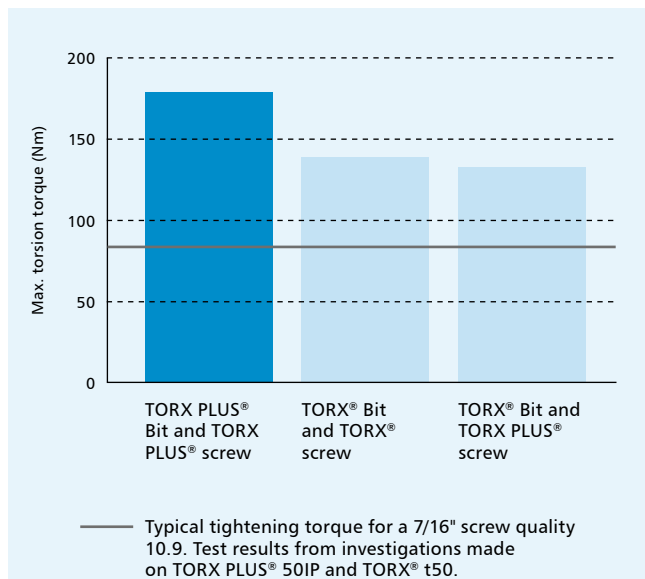

TORX PLUS[®] gives greater assembly reliability – even when the screw is undone.

Different types of force application compared

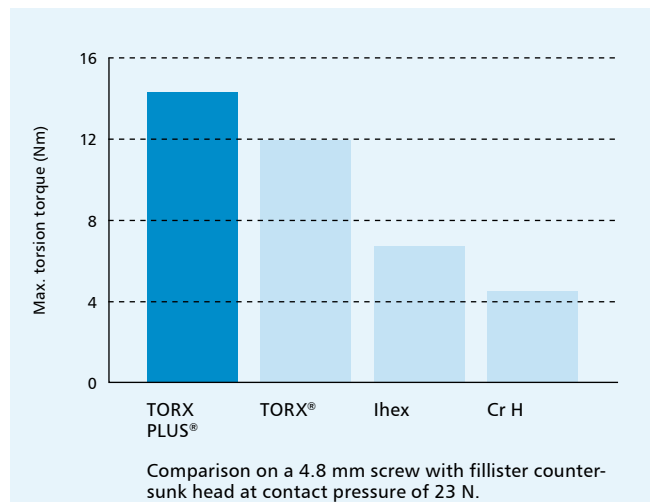

TORX PLUS[®] transfers higher torques.

TORX[®], TORX PLUS[®] and AUTOSERT[®] are registered trademarks of Camcar, Division of Textron, Rockford IL.

TORX PLUS® with AUTOSERT® special shape for automated assembly

You know about the problem of constantly rotating bits on the assembly line often causing malfunctions because the screwdrivers do not engage correctly. With the recently developed AUTOSERT® characteristic the screwdriver can rotate at a speed of 700 rpm, and with reliable engagement of bit with screw. With manual assembly jobs AUTOSERT® eases the screwdriving task with angle and axis offset between the bit and the screw.

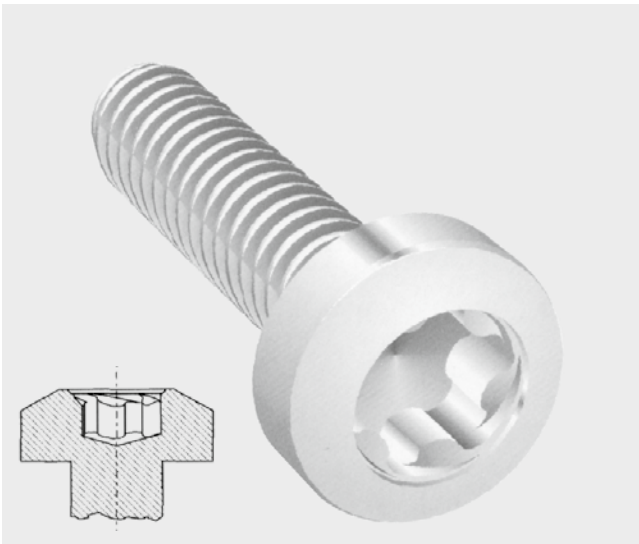

Other versions of the TORX PLUS® drive system

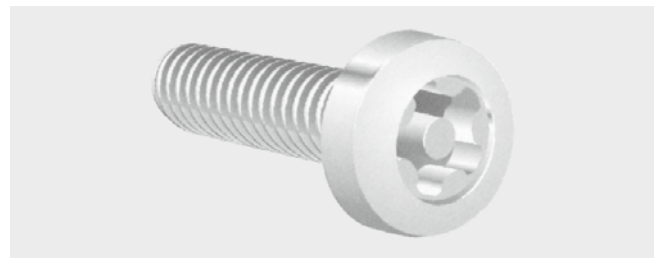

SAFETY TORX PLUS®

Safety driver with 5 engagement nubs and safety taps

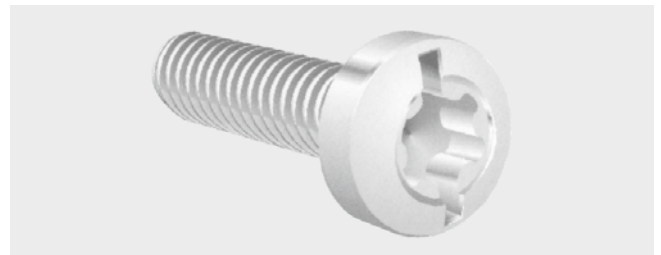

Combi TORX PLUS®

Can be deployed universally, because two screwdriving systems are possible

TORX PLUS® and TORX® sizes for threaded screws

| Nominal Ø | TORX PLUS | TORX® |
|-----------|-----------|-------|
| M3 | 10 IP | T10 |
| M3.5 | 15 IP | T15 |
| M4 | 20 IP | T20 |
| M5 | 25 IP | T25 |
| M6 | 30 IP | T30 |
| M8 | 40 IP | T40 |
| M10 | 50 IP | T50 |

Minimum transferable torque for tools in Nm

| Size | TORX® | TORX PLUS® |
|------|--------|------------|
| 10 | 4.52 | 5.42 |
| 15 | 7.69 | 9.62 |
| 20 | 12.66 | 16.10 |
| 25 | 18.99 | 23.50 |
| 30 | 37.40 | 47.20 |
| 40 | 65.08 | 82.10 |
| 50 | 158.75 | 194.50 |

ARNOLD FASTENING SYSTEMS Inc.

1873 Rochester Industrial Ct.,
Rochester Hills, MI 48309-3336
USA
T +1 248 997-2000
F +1 248 475-9470

ARNOLD UMFORMTECHNIK GmbH & Co. KG

Carl-Arnold-Straße 25
74670 Forchtenberg-Ernsbach
Germany
T +49 7947 821-0
F +49 7947 821-111

ARNOLD UMFORMTECHNIK GmbH & Co. KG

Max-Planck-Straße 19
74677 Dörzbach
Germany
T +49 7947 821-0
F +49 7947 821-111

ARNOLD FASTENERS (SHENYANG) Co., Ltd.

No. 119-2 Jianshe Road
110122 Shenyang
China
T +86 24887 90633
F +86 24887 90999