

## TriPress<sup>®</sup> Plus

Great reduction in assembly time

- + Shorter cycle times
- + Small installation
- + Tamper-proof
- + Vibration resistance
- + Small pre-stress forces
- + Multiple element

All Parts  
from  
climate-neutral  
production  
since 2022



# 100%

## System solution from a single source

Our key elements are the feeder, the tool, and the fastener element. You can also obtain from us complete systems, process monitoring solutions, as well as a full service package for your new project.



## The TriPress® Plus effect

### Huge time saving

➤ Positioning time is greatly shortened compared with a screw. It is independent of the ratio between speed and pitch, because the TriPress® Plus is simply pressed in axially.

### Tamper-proof

➤ The TriPress® plus cannot be undone without destroying the fastening. Which means that your components are secured against theft and tampering.

### Independent of pre-stress forces

➤ The holding power of the TriPress® Plus is independent of the clamp load. And applications without a clamping part present no problem.

### Small installation space

➤ The TriPress® Plus is distinctive for its excellent holding forces but with low press-in depths, as well as its flat head.

# TriPress<sup>®</sup> Plus

## The fundamentals of joining in four steps

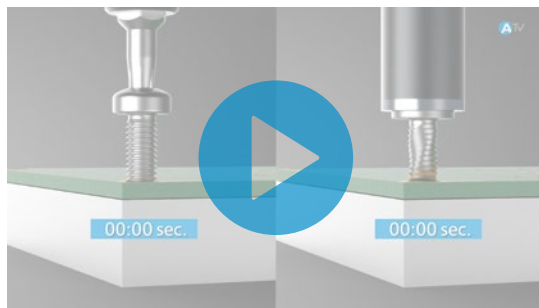

### Rapid fastenings with clinch fasteners

The TriPress<sup>®</sup> Plus rapid fastener can be inserted automatically, semi-automatically, or using manual pressing technologies. Full automation, combined with servo-presses, provide maximum cycle time and process reliability.

The quick lift moves the TriPress<sup>®</sup> Plus towards the press-in point and presses it into the component with a purely axial movement.

Where a servopress is used, it will accurately detect the head setting and will apply a defined pressing force. The press-on force generates a pre-clamp load by creating elastic check for deformation in the clamping part, and thus securely fastens the components together.

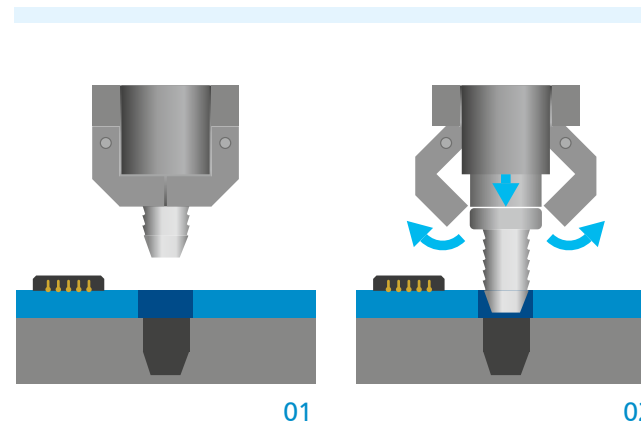

01 | Position:  
Fix the component

02 | Quick lift:  
Move the component forward

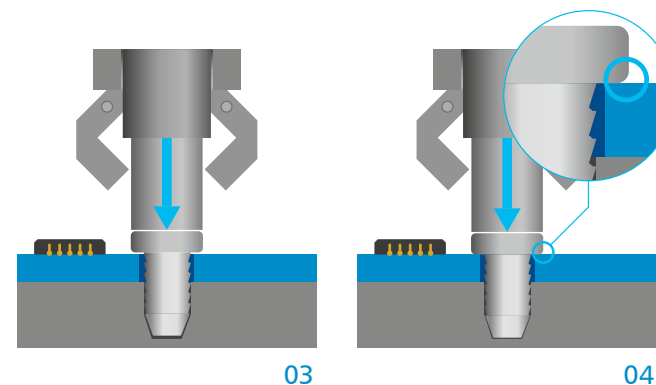

03 | Clinching

04 | Detect head setting,  
switch off, and concede  
power or path

# TriPress® Plus

## Efficient to use, convincing comparisons

You can join two components quickly and economically by pressing in the TriPress® Plus fastener.

TriPress® Plus

### Top Features

#### The advantages over screw fastenings

- ➊ Great reduction in assembly time
- ➋ Smaller installation space
- ➌ No torsion stress in the component
- ➍ Tamper-proof
- ➎ No self-actuating loosening

#### The advantages over moulded elements (in plastics)

- ➊ No need to insert metal parts into injection moulds
- ➋ Shorter cycle times (injection moulding)
- ➌ No lost fastener elements

### Innovative Fastening and Engineering Solutions

TriPress® Plus is a triangular quick fastening system that can be clinched into plastic, light metals and steel. You can join two components quickly and economically by pressing in the TriPress® Plus fastener.

### Application areas

#### Materials

- ➊ Plastic
- ➋ Light metal
- ➌ Copper
- ➍ Steel

#### Dimensions

TriPress® Plus is particularly appropriate where dimensions are small. Discover our sizes in the 2.9-5.7 range

#### Performance

With its optimised shaft geometry TriPress® Plus provides improved pull-out values.

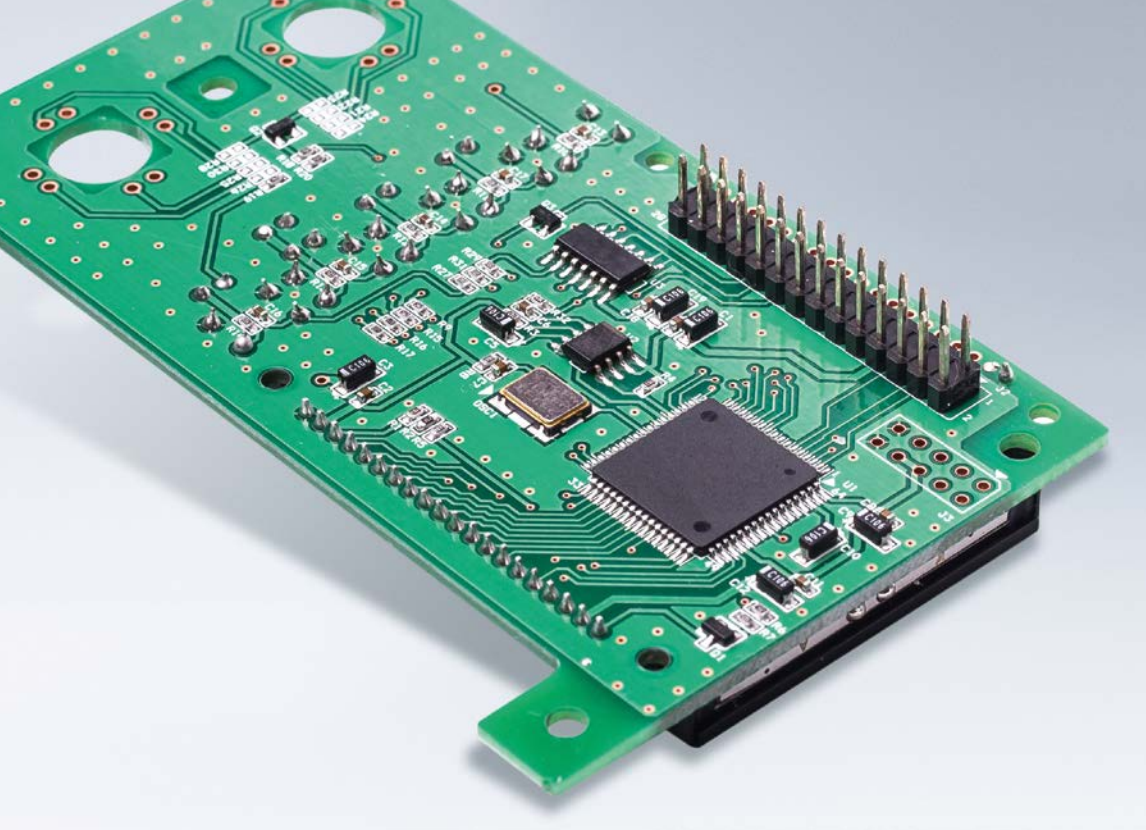

## Electronics applications

Linear clinching with no rotary movement minimises stress on the PCB. The flat head allows for compact construction.

## Aluminium and metal applications

TriPress<sup>®</sup> Plus fasteners create friction and positive lock fastenings and achieve high torsional torques and pull-out forces.



shutterstock-ID: 1464873023 | © Wellnhofer Designs

## Plastic-to-metal fasteners

Circumferential locking flutes on triangular shaft generate high pull-out resistance.



shutterstock-ID: 1546706552 | © yamik88

# The great strength Circumferential locking flutes

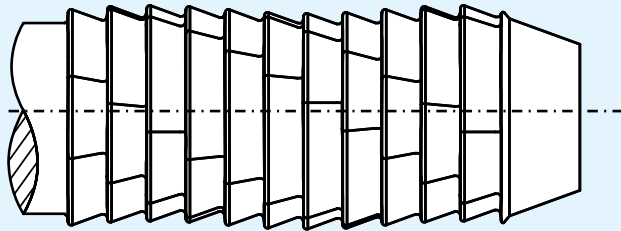

Circumferential locking flutes on triangular shaft for

- ② Very high pull-out forces
- ② Rapid fixing of clamping part

## The advantages over screw fastenings



Load-carrying and positive-lock fastening

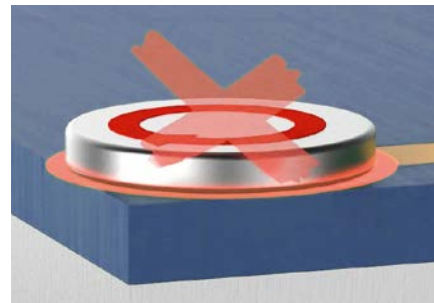

No torsion stresses on the circuit board

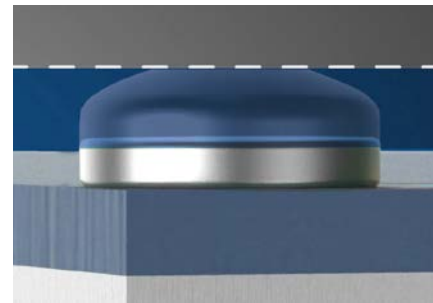

Overall height reduced by up to 70%

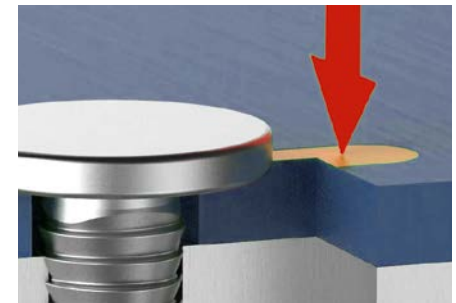

Ground connection PCB / bolt possible

1st to 3rd knurl can be under-size. Transition angle from crest to 1st knurl permitted.

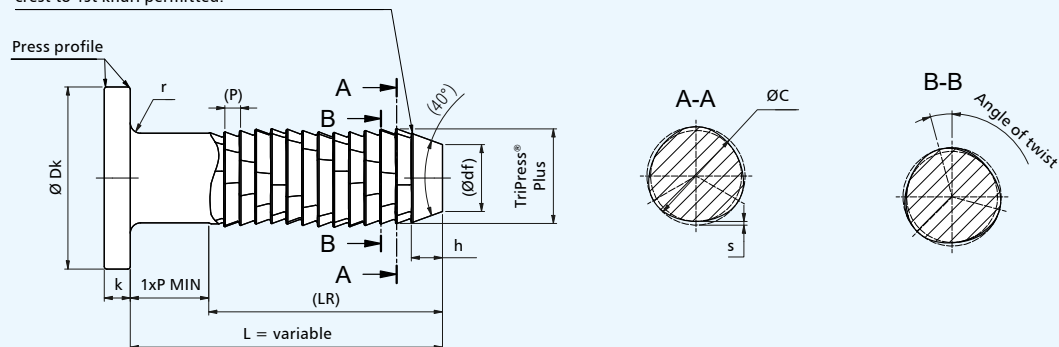

### Head variant: TriPress® Plus K

The TriPress® Plus fastens components quickly and torsion-free. The elastic check for deformation in the clamping part achieves a low pre-clamp load.

- ➊ Very high pull-out forces
- ➋ Rapid fixing of clamping part

TriPress® Plus nom. Ø d	2.9	3.3	3.8	4.8	5.7
(P)	0.50	0.50	0.60	0.80	0.80
ØC	2.85	3.27	3.78	4.75	5.66
s	0.10	0.12	0.14	0.16	0.20
$k_{0,2}$	0.80	0.80	1.00	1.50	1.80
$ØD_{K-0,3}$	5.60	6.00	7.00	8.00	10.00
r ca.	0.30	0.35	0.40	0.50	0.60
(Ødf)	1.86	2.29	2.55	3.18	4.01
h	1.00	1.00	1.20	1.60	1.60
(LR) MIN	5.00	5.00	6.00	7.00	7.00

Length L <sub>total</sub>	Tolerance
> 3 – 6	±0.24
> 6 – 10	±0.29
> 10 – 18	±0.35
> 18 – 30	±0.42
> 30 – 50	±0.50
> 50 – 80	±0.60

All dimensions are in mm. Other dimensions supplied on request.

## Fitting recommendations for ductile light metals

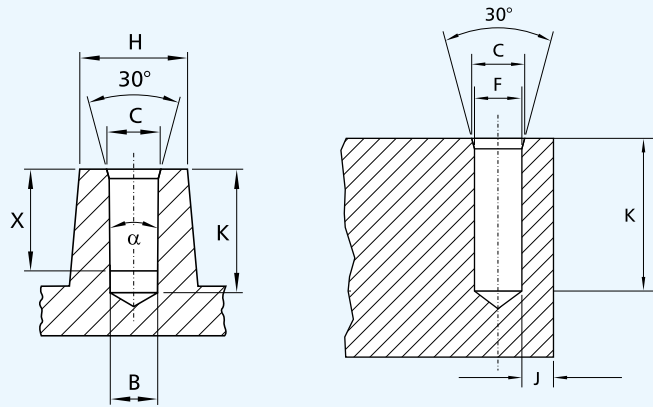

Core hole recommendation for cast holes.  
Max. draft angle  $\alpha = 1^\circ$

Tolerance range H11  
for bore diameter F

### Core hole diameter recommendations for light metal<sup>1</sup>

Applicable to the head variant (K)

Variant	depth X	Core hole depth $K_{min}$
Head (K)	Max press-in depth – (5xP)	$X + (5xP) + h + 1 \text{ mm}$

TriPress® Plus nom. Ø	Ø C	Cast core hole Ø B at depth X	Drilled core hole Ø F	Minimum tube Ø H	Minimum distance From edge J
2.9	2.90	2.63	2.65	5.60	1.40
3.3	3.40	3.06	3.10	6.60	1.60
3.8	3.80	3.48	3.50	7.40	1.80
4.8	4.80	4.40	4.40	9.20	2.30
5.7	5.60	5.26	5.30	10.80	2.70

### Recommendation for determining the TriPress® Plus design

**For high tensile stress and low torsion stress:**

TriPress® Plus with circumferential locking flutes and spiral triangular cross-section, hardened and tempered (FK 10).

Recommended press-in depth:  $X = 1.5 - 2.5 \times \text{Nominal } \varnothing$

All dimensions are in mm. Other dimensions supplied on request.



## Fitting recommendations for ductile plastics

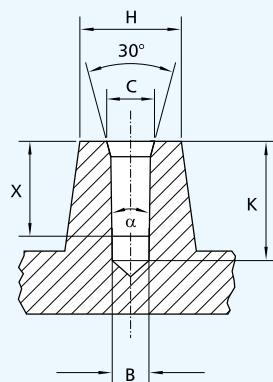

Core hole recommendation for cast holes.  
Max. draft angle  $\alpha = 1^\circ$

### Core hole diameter recommendations for plastics<sup>1</sup>

Applicable to the head variant (K).

<sup>1)</sup> The below dimensions are merely guidelines, based principally on theoretical calculations. It is therefore important that you carry out the relevant laboratory trials using production parts in order to determine the precise parameters (clinching and press-out forces), core hole diameters, torsion moments etc.)

Variant	depth X	Core hole depth $K_{min}$
Head (K)	Max press-in depth – (5xP)	$X + (5xP) + h + 1 \text{ mm}$

### Recommendation for determining the design TriPress® Plus

#### For high tensile stress and low torsion stress:

TriPress® Plus with circumferential locking flutes and spiral triangular cross-section, hardened and tempered (FK 8 or 10).

Recommended press-in depth:  $X = 2.0 - 4.0 \times \text{Nominal } \varnothing$

All dimensions are in mm. Other dimensions supplied on request.

TriPress® Plus nom. $\varnothing$	$\varnothing C$	PA	PA6	PP	ABS	PC-ABS	PC	PE	PPO	PMMA
		Core-hole $\varnothing B$								
2.9	2.90	2.50	2.50	2.50	2.50	2.60	2.60	2.50	2.60	2.60
3.3	3.40	3.00	3.00	3.00	3.00	3.10	3.00	3.00	3.00	3.00
3.8	3.80	3.45	3.50	3.45	3.50	3.50	3.50	3.45	3.50	3.50
4.8	4.80	4.30	4.35	4.20	4.30	4.30	4.40	4.30	4.30	4.40
5.7	5.60	5.00	5.10	5.00	5.10	5.10	5.10	5.00	5.10	5.10

# System technology and processing from TriPress® Plus

## Tool technology

### Setting tools

#### Variants

- ② Single head setting tools
- ② Multiple head setting tools

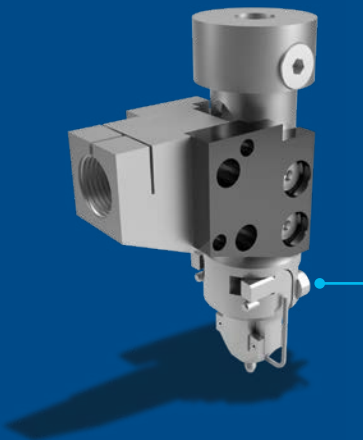

#### Product characteristics

- ② Tight processing distances possible
- ② Can insert into recesses (up to 50 mm)
- ② Rapid processing speed (cycle time  $\leq 2$  sec.)



## Drive technology

### HMI for control and visualization

#### Product characteristics

- ② Control system centrally positioned inside control cabinet
- ② Local hardware components (valves, sensors, actuators) positioned outside control cabinet
- ② Hardware components connected via bus system
- ② A single controller can control several press-fit systems
- ② Interfaces with robots, higher-level systems (such as MES)
- ② System configured from external PC or on (optional) operating panel



## Pressing modules

Standardised modules can be supplied for integration into processing plant or as a stand-alone solution.



### Drive technology: variants

- ② servo-motor driven

### Press frame: Variants

- ② C-bracket in fired or welded style
- ② 2 or 4 column frames
- ② Can be adapted individually to suit customer requirements
- ② Supplied as standalone solution or for integration into customer's own solution

## Sorting and feeding technology

### Step feeder

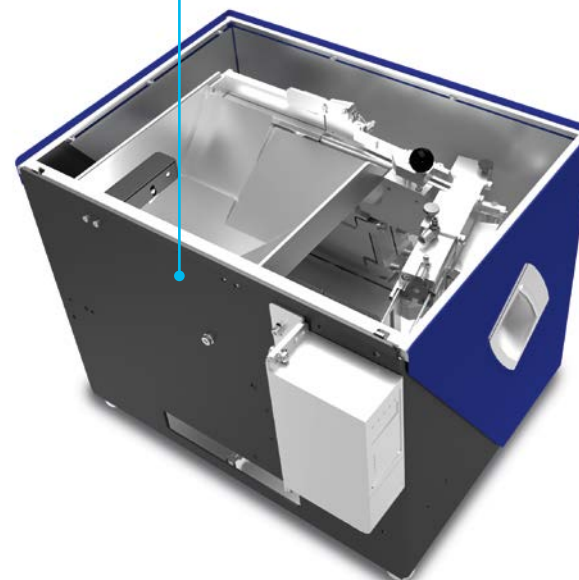

### Product characteristics

- ② Gentle sorting action, low abrasion
- ② Suitable for minimal sizes (dia.  $\geq 2.0$  mm)
- ② Compact design
- ② Easy adaptation to fastener's geometry
- ② Separates singly or in multiples (to supply up to four processing tools)
- ② Top sorting performance (65 press-fit fasteners per minute)
- ② Feeds to tool through a protective hose

### Optional equipment

- ② Dirt extraction port
- ② Replaceable filter cartridge, 5  $\mu$ m filtration rating
- ② Stock bin container (up to 5 litres)



# The ARNOLD GROUP

[www.arnold-fastening.com](http://www.arnold-fastening.com)

Wherever customers need us.

**ARNOLD – this name is internationally renowned for efficient and sustainable fastening systems at the highest level.**

With a foundation of many years of expertise in the production of intelligent fastening systems and very complex extruded parts, the ARNOLD GROUP has developed over a number of years into a comprehensive supplier and development partner for complex fastening systems. With our positioning of "BlueFastening Systems", this

development process will continue under a united and harmonised structure. Engineering, services, fasteners and functional parts, together with feeding and processing systems, all from a single source – efficient, sustainable and international.

### ARNOLD UMFORMTECHNIK GmbH & Co. KG

Carl-Arnold-Straße 25  
74670 Forchtenberg-Ernstbach  
Germany  
T +497947821-0  
F +497947821-111



### ARNOLD UMFORMTECHNIK GmbH & Co. KG

Im Weitblick 1  
74670 Forchtenberg  
Germany  
T +49 7947 821-0  
F +49 7947 821-111



### ARNOLD UMFORMTECHNIK GmbH & Co. KG

Max-Planck-Straße 19  
74677 Dörzbach  
Germany  
T +497947821-0  
F +497947821-111



### ARNOLD FASTENING SYSTEMS Inc.

1873 Rochester Industrial Ct.  
Rochester Hills, MI 48309-3336  
USA  
T +1248997-2000  
F +1248475-9470



### ARNOLD FASTENERS (SHENYANG) Co., Ltd.

No. 119-2 Jianshe Road  
110122 Shenyang  
China  
T +862488790633  
F +862488790999

